



www.landgraff.no

Kapittel 3

TRINSER SYKEHUS

A.C. LANDGRAFF AS ble grunnlagt i Oslo 1947. Firmaet har fra starten spesialisert seg på hjul og trinser. Det ble produsert egne hjul i nært samarbeid med kunden, spesielt for slakterier og fiskeindustrien.

I dag importeres det meste som ferdigvare og halvfabrikat. Vi har et stort og rikholdig lager av hjul, gaffler, lager, dekk, slanger osv. som gjør at vi kan skreddersy de beste løsninger for spesielle ønsker og behov.

Vare sortimentet utvides stadig:

- Spesialhjul og deler for rullestoler m.m.
- Holker, plastinnsatser, stillskruer, låseratt m.m.
- Gassfjærer med diverse spesialtilpasninger.
- Traller vogner.
- Formstøpte PUR deler som armlener, leggputer m.m.

Vi representerer noen av de ledende produsenter på sine områder:



SVINGKRANSLAGER

Svingegenskapene til en trinse, påvirkes av forskjellige faktorer som utbygg, hjuldiameter og ikke minst konstruksjonen av svingkransen.

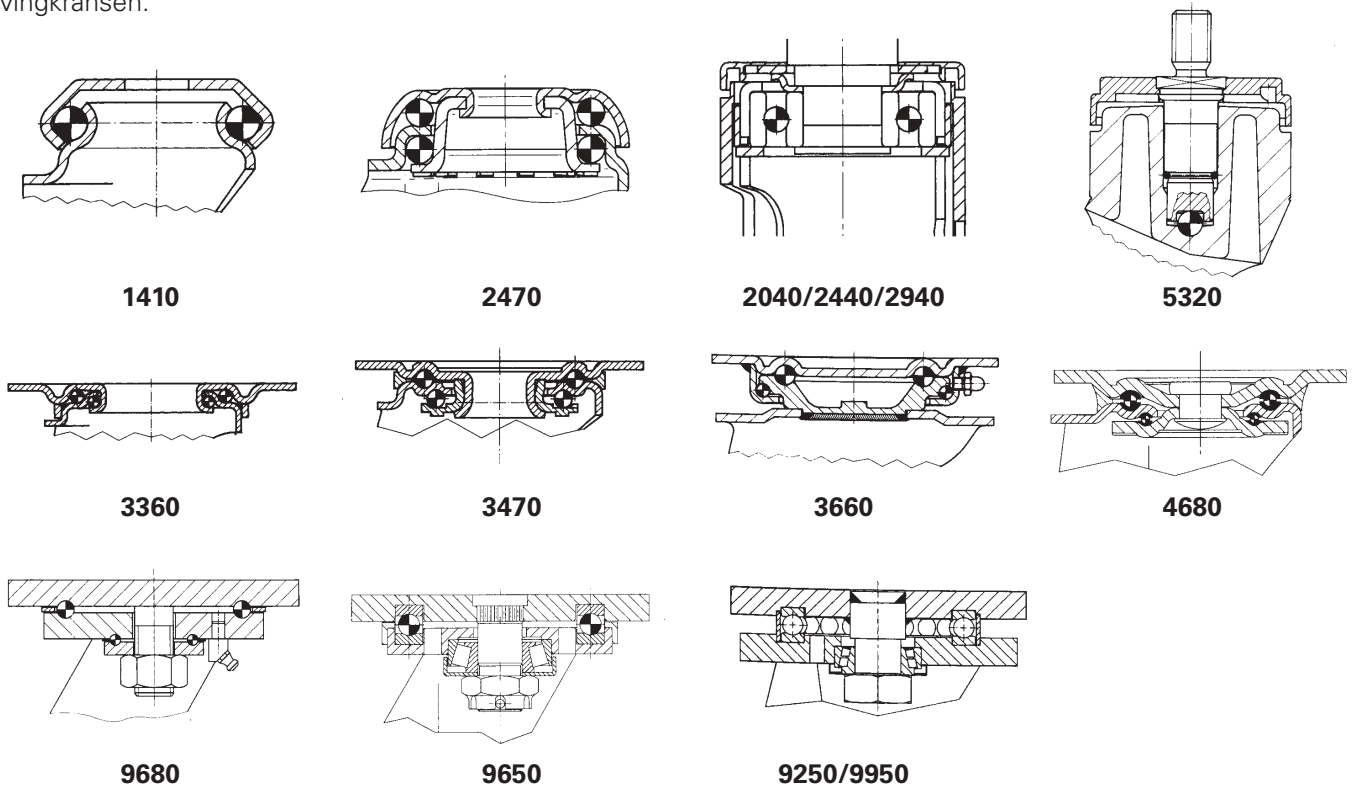

HJULLAGER

- KULELAGER:** Har lavest rullemotstand, høyest bæreevne og lang levetid selv ved kontinuerlig bruk.
RULLELAGER: Er robuste og anvendes i industrihjul hvor hastigheten ikke overstiger 5 km/t.
GLIDELAGER: Er nesten vedlikeholdsfrie og tåler støt+slag, egner seg best for vogner med korte rulleavstander.

BELASTNING: Grunnregelen for å velge riktig hjul/trinse:

$$\frac{\text{Vognens egenvekt} + \text{last}}{3}$$

3 hjul/trinse skal kunne bære totalvekten, et hjul kan være uten bakkekontakt hvis underlaget er ujevnt.

KONSTRUKSJONSBESKRIVELSER AV HJUL OG TRINSE

HJUL

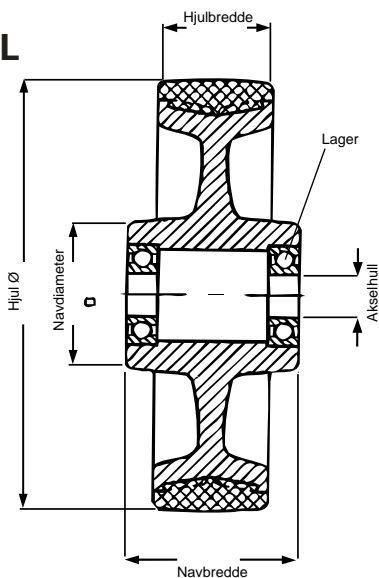

TRINSE

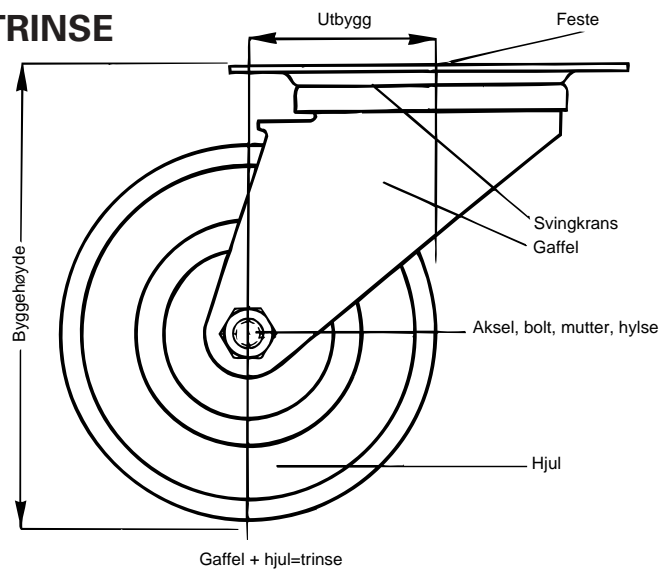

5474/5476 - TRINSER FOR PLEIEHJEMSENGER "DECORA"

- Dobbel kulebane i svingkrans
- Gaffel av elforzinket presset stålplate
- Grå gummi på plastfelg m/kulelager, trådbeskyttere
- 5476 sentral lås, totalbrems
- 5474 sentral lås, total eller retningsbrems



mm	mm	mm	mm	mm	mm	kg (daN)	Totalbrems
100	32	138	38	28	96	80	5476 PJP 100 R26-28
125	32	163	41	28	96	80	5476 PJP 125 R26-28



mm	mm	mm	mm	mm	mm	kg (daN)	Totalbrems eller retningslås
100	32	138	38	28	96	80	5474 PJP 100 R26-28
125	32	163	41	28	96	80	5474 PJP 125 R26-28



mm	mm	mm	mm	mm	mm	kg (daN)	Svingbar trinse
100	32	138	38	28	45	80	5470 PJP 100 R05-28
125	32	163	41	28	45	80	5470 PJP 125 R05-28

 Rote Punkt (Red Dot) design pris.

2474/2476 - TRINSER FOR SYKEHUSSENGER

- Dobbel kulebane i svingkrans
- Gaffel av elforzinket presset stålplate
- Grå gummi på plastfelg m/kulelager, trådbeskyttere
- 2476 sentral lås, totalbrems
- 2474 sentral lås, total eller retningsbrems



mm	mm	mm	mm	mm	mm	kg (daN)	Totalbrems
100	32	138	38	28	96	100	2476 PJP 100 R26-28
125	32	163	41	28	96	100	2476 PJP 125 R26-28
150	32	188	45	28	96	100	2476 PJP 150 R26-28



mm	mm	mm	mm	mm	mm	kg (daN)	Totalbrems eller retningslås
100	32	138	38	28	96	100	2474 PJP 100 R26-28
125	32	163	41	28	96	100	2474 PJP 125 R26-28
150	32	188	45	28	96	100	2474 PJP 150 R26-28



mm	mm	mm	mm	mm	mm	kg (daN)	Svingbar trinse
100	32	138	38	28	45	100	2470 PJP 100 R05
125	32	163	41	28	45	100	2470 PJP 125 R05
150	32	188	45	28	45	100	2470 PJP 150 R05

ALTERNATIVE HJUL



DIK



DYK/JYP
Antistatisk ESD



XSX
Antistatisk ESD



UAP



R36-32 kort stamme









Overgangshylser







2044/2046 - TRINSER FOR SYKEHUSSENGER "INTEGRAL"

- Presisjonskulelager, i svingkrans m/tetning
- Doble kulelager i navet
- Bærende gaffel i gulchromatisert stål
- Heldekkende kappe av kunststoff
- 2046 total lås
- 2044 total lås eller retningslås
- Hjul grå polyuretan på kunststoffelg











 mm	 mm	 mm	 mm	 mm	 mm	 kg (daN)	Totalbrems
125	32	158	35	28	96	150	2046 UAP 125 R26-28
150	32	183	40	28	96	150	2046 UAP 150 R26-28
200	32	229	60	28	96	150	2046 UAX 200 R26-28



 mm	 mm	 mm	 mm	 mm	 mm	 kg (daN)	Totalbrems eller retningslås
125	32	158	35	28	96	150	2044 UAP 125 R26-28
150	32	183	40	28	96	150	2044 UAP 150 R26-28
200	32	229	60	28	96	150	2044 UAX 200 R26-28



 mm	 mm	 mm	 mm	 mm	 mm	 kg (daN)	Svingbar trinse
125	32	158	35	28	45	150	2040 UAP 125 R05-28
150	32	183	40	28	45	150	2040 UAP 150 R05-28
200	32	229	60	28	45	150	2040 UAX 200 R05-28







 IF pris for god design.

 Rote Punkt (Red Dot) design pris.







2944/2946 - TVILLINGTRINSER FOR SYKEHUSSENGER

- Presisjonskulelager, i svingkrans m/tetning
- Doble kulelager i navet
- Gaffelen består av en kraftig stålplateramme, elforzinket bekledd m/nylon
- 2946 total lås
- 2944 total lås eller retningslås
- Polyuretanbane på nylonfelg









 mm	 mm	 mm	 mm	 mm	 mm	 kg (daN)	Totalbrems
100	60	129	31	28	96	125	2946 UAP 100 R26-28
125	60	150	37,5	28	96	125	2946 UAP 125 R26-28
150	70	175	45	28	96	150	2946 UAP 150 R26-28



 mm	 mm	 mm	 mm	 mm	 mm	 kg (daN)	Totalbrems eller retningslås
100	60	129	31	28	96	125	2944 UAP 100 R26-28
125	60	150	37,5	28	96	125	2944 UAP 125 R26-28
150	70	175	45	28	96	150	2944 UAP 150 R26-28



 mm	 mm	 mm	 mm	 mm	 mm	 kg (daN)	Svingbar trinse
125	60	150	37,5	28	45	125	2940 UAP 125 R05-28
150	70	175	45	28	45	150	2940 UAP 150 R05-28

 Rote Punkt (Red Dot) design pris.

ALTERNATIVE HJUL



XSX Antistatisk



Antistatisk XSX



Kan leveres rustfritt
7040/7044/7046 UAX

1. Leveringsbetingelser

Rettsforholdet mellom kjøper og A.C.LANDGRAFF AS (ACL) bedømmes etter norsk lov med nedenforstående endringer.

2. Tilbud og priser

Muntlige tilbud skal aksepteres straks, ellers er de å regne som bortfalt. Skriftlige tilbud er gjeldende i 28 dager etter tilbudsdato såfremt annet ikke er notert, deretter er tilbudet bortfalt. Prisen er forbeholdt for lønns- og materialpris-stigning samt svingninger i valutakursene.

3. Levering

Levering skjer med mindre annet er avtalt fritt vårt lager. Spesialproduserte varer, herunder spesialfarver kan over/under leveres med 10%

Ordre under det til enhver tid gjeldende minimum kjøp tillegges det til enhver tid gjeldende småordretillegg. Pr. i dag tillegges ordre under kr. 300,- et tillegg på kr. 40,-.

Retur av varer kan kun skje etter avtale og skal da sendes fritt vårt lager. Ved retur beregnes et returgebyr på 10% dog minimum kr. 150,-.

4. Mangler og ansvar

Reklamasjoner over antallsmangler skal skje straks etter mottagelsen av varene ellers bortfaller reklamasjonsretten. Reklamasjoner over øvrige mangler skal skje innen 8 dager fra mottagelsen ellers bortfaller reklamasjonsretten. Vårt ansvar er begrenset til ny levering med reklamasjonsfri vare eller maksimert til faktura-beløpet, etter vårt valg.

5. Force majeure

Følgende utvidede force majeure fritar ACL for forsinkelsesansvar: Krig, brann, streik, lockout, vær, ut-og innførselsforbud, beslagleggelser eller forsinkelser fra underleverandører eller andre omstendigheter som ACL ikke forutså eller burde ha forutsett.

6. Produktansvar

Selgeren er ikke ansvarlig for skade på produkter som er fremstilt av kjøperen. Selgeren er ikke ansvarlig for driftstap, tapt arbeidsfortjeneste eller annet indirekte tap.

7. Generelt

Alle mål, farveangivelser, belastningsoppgaver m.m. kan endres uten forvarsel.

8. Kvalitetssikring

De fleste av våre leverandører er ISO 9001-sertifisert.

A.C. Landgraff AS

P. boks 14, N-1305 Haslum
Nesveien 13, N-1344 Haslum
Tlf.: (+47) 67 52 60 00
Faks: (+47) 67 53 88 12
e-post: landgraff@landgraff.no
www.landgraff.no