



[www.landgraff.no](http://www.landgraff.no)

## Kapittel 6

# TRINSER RUSTFRI

**A.C. LANDGRAFF AS** ble grunnlagt i Oslo 1947. Firmaet har fra starten spesialisert seg på hjul og trinser. Det ble produsert egne hjul i nært samarbeid med kunden, spesielt for slakterier og fiskeindustrien.

I dag importeres det meste som ferdigvare og halvfabrikat. Vi har et stort og rikholdig lager av hjul, gaffler, lager, dekk, slanger osv. som gjør at vi kan skreddersy de beste løsninger for spesielle ønsker og behov.

Vare sortimentet utvides stadig:

- Spesialhjul og deler for rullestoler m.m.
- Holker, plastinnsatser, stillskruer, låseratt m.m.
- Gassfjærer med diverse spesialtilpasninger.
- Traller vogner.
- Formstøpte PUR deler som armlener, leggputer m.m.

Vi representerer noen av de ledende produsenter på sine områder:



## SVINGKRANSLAGER

Svingegenskapene til en trinse, påvirkes av forskjellige faktorer som utbygg, hjuldiameter og ikke minst konstruksjonen av svingkransen.

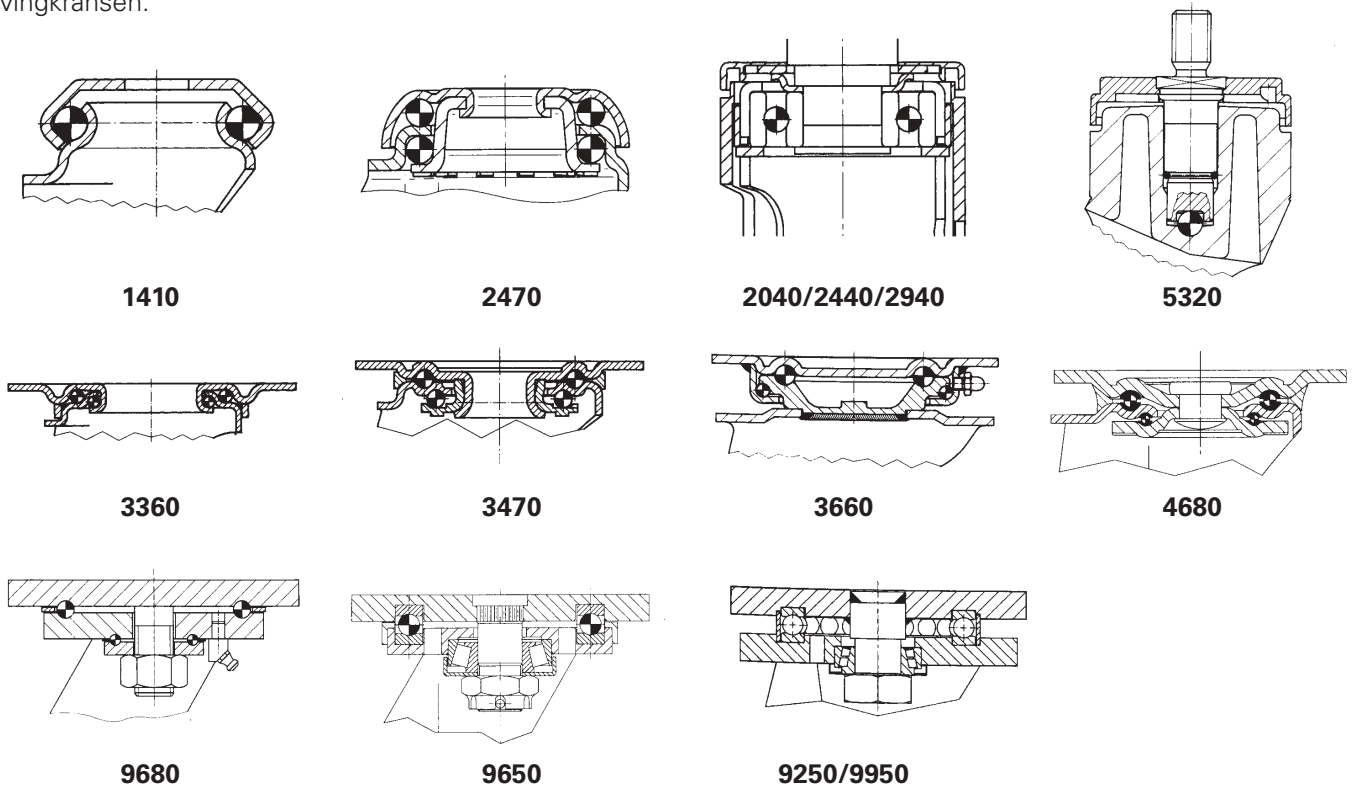

## HJULLAGER

- KULELAGER:** Har lavest rullemotstand, høyest bæreevne og lang levetid selv ved kontinuerlig bruk.  
**RULLELAGER:** Er robuste og anvendes i industrihjul hvor hastigheten ikke overstiger 5 km/t.  
**GLIDELAGER:** Er nesten vedlikeholdsfrie og tåler støt+slag, egner seg best for vogner med korte rulleavstander.

**BELASTNING:** Grunnregelen for å velge riktig hjul/trinse:

$$\frac{\text{Vognens egenvekt} + \text{last}}{3}$$

3 hjul/trinse skal kunne bære totalvekten, et hjul kan være uten bakkekontakt hvis underlaget er ujevnt.

## KONSTRUKSJONSBEKRIVELSER AV HJUL OG TRINSE

### HJUL

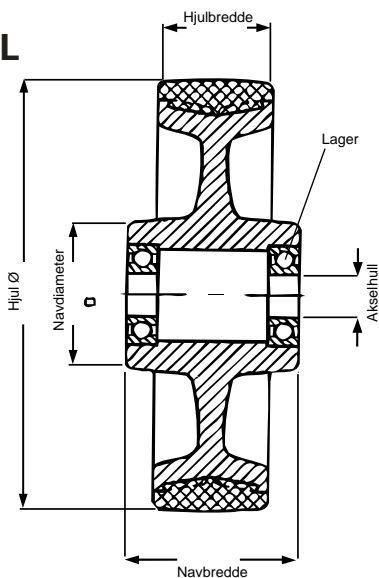

### TRINSE

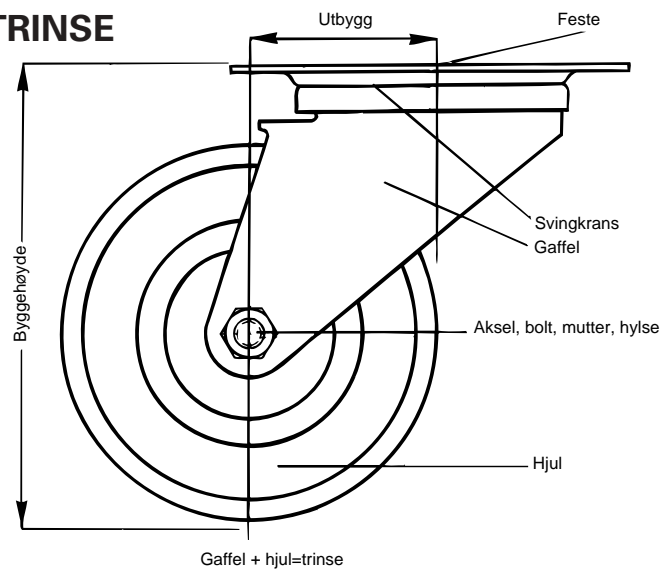

## 7670/7470 - P30 RUSTFRIE TRINSER

- Dobbel kulebane i svingkrans
- Gaffel av presset rustfritt stål

- Termoplastisk gummibane m/glidelager
- Bremsen låser hjul og sving i en operasjon



mm	mm	mm	mm	mm			kg (daN)	Bestillingsnr. sving
060	22	87	27	10			40	<b>7470 PJO 060 P30</b>
080	22	107	30	10			50	<b>7470 PJO 080 P30</b>
100	22	127	35	10			60	<b>7470 PJO 100x22 P30</b>
100	32	132	40	10			80	<b>7670 PJO 100x32 P30</b>
125	32	159	43	10			100	<b>7670 PJO 125 P30</b>
150	30	185	48	12			100	<b>7470 PJO 150 P30</b>



Sving m/brems								
060	22	87	27	10			40	<b>7477 PJO 060 P30 +</b>
080	22	107	30	10			50	<b>7477 PJO 080 P30 +</b>
100	22	127	35	10			60	<b>7477 PJO 100x22 P30 +</b>
100	32	132	40	10			80	<b>7677 PJO 100x32 P30</b>
125	32	159	43	10			100	<b>7677 PJO 125 P30</b>
150	30	185	48	12			100	<b>7470 PJO 150 P30 +</b>

## 7670/7470 - P60 RUSTFRIE TRINSER



mm	mm	mm	mm	mm	mm	mm	kg (daN)	Svingbar trinse
060	22	89	27	50x65	36x50	6,5	40	<b>7470 PJO 060 P60</b>
080	22	109	30	50x65	36x50	6,5	50	<b>7470 PJO 080 P60</b>
100	22	129	35	50x65	36x50	6,5	60	<b>7470 PJO 100x22 P60</b>
100	32	135	43	77x67	55x45	8,5	80	<b>7670 PJO 100x32 P50</b>
125	32	159	43	77x67	55x45	8,5	100	<b>7670 PJO 125 P50</b>
125	32	160	43	95x70	75x50	11,0	100	<b>7670 PJO 125 P51*</b>
150	30	188	48	70x90	50x70	8,5	100	<b>7470 PJO 150 P60</b>



Fast trinse								
060	22	89		50x65	36x50	6,5	40	<b>7478 PJO 060 P60</b>
080	22	109		50x65	36x50	6,5	50	<b>7478 PJO 080 P60</b>
100	22	129		50x65	36x50	6,5	60	<b>7478 PJO 100x22 P60</b>
100	32	135		77x67	55x45	8,5	80	<b>7678 PJO 100x32 P50</b>
125	32	159		77x67	55x45	8,5	100	<b>7678 PJO 125 P50</b>
125	32	160		95x70	75x50	11,0	100	<b>7678 PJO 125 P51*</b>
150	30	188		70x90	50x70	8,5	100	<b>7478 PJO 150 P60</b>



Svingbar trinse m/brems								
060	22	89	27	50x65	36x50	6,5	40	<b>7477 PJO 060 P60 +</b>
080	22	109	30	50x65	36x50	6,5	50	<b>7477 PJO 080 P60 +</b>
100	22	129	35	50x65	36x50	6,5	60	<b>7477 PJO 100x22 P60 +</b>
100	32	135	43	77x67	55x45	8,5	80	<b>7677 PJO 100x32 P50</b>
125	32	159	43	77x67	55x45	8,5	100	<b>7677 PJO 125 P50</b>
125	32	160	43	95x70	75x50	11,0	100	<b>7677 PJO 125 P51*</b>
150	30	188	48	70x90	50x70	8,5	100	<b>7477 PJO 150 P60 +</b>

\* Stor plate etter DIN 18 867 nr. 8 (trinser for storkjøkken utstyr)

## 7970 - P53 RUSTFRI TVILLINGTRINSE



mm	mm	mm	mm	mm	mm	mm	kg (daN)	Svingbar trinse
075	2x25	101	28	70x55	54x45	5,5	100	<b>7970 PJO 075 P53</b>

### ALTERNATIVER



+ 7477/P30



+ 7477/P60



Tapp R05



Rustfri kulelager PJX

## 8470 - P60 UFX RUSTFRIE TRINSER

- Dobbel kulebane i svingkrans rustfrie kuler
- Tetning i svingkrans
- Gaffel og festeplate av presset rustfri stålplate
- Hjul elastisk grå gummi meget myk og lettrullende
- **UFD** elastisk gummi på nylonfelg m/rullelager
- **UFX** elastisk gummi på nylonfelg m/tette kulelager



mm	mm	mm	mm	mm	mm	mm	kg (daN)	Svingbar trinse
100	34	128	40	105x85	80x60	9	150	<b>8470 UFD 100 P62</b>
125	40	155	45	105x85	80x60	9	250	<b>8470 UFX 125 P62</b>
160	46	195	60	140x110	105x80	11	300	<b>8470 UFX 160 P63</b>
200	46	235	60	140x110	105x80	11	300	<b>8470 UFX 200 P63</b>



mm	mm	mm	mm	mm	mm	mm	kg (daN)	Fast trinse
100	34	128	40	105x85	80x60	9	150	<b>8478 UFD 100 P62</b>
125	40	155	45	105x85	80x60	9	250	<b>8478 UFX 125 P62</b>
160	46	195	60	140x110	105x80	11	300	<b>8478 UFX 160 P63</b>
200	46	235	60	140x110	105x80	11	300	<b>8478 UFX 200 P63</b>



mm	mm	mm	mm	mm	mm	mm	kg (daN)	Svingbar trinse m/brems
100	34	128	40	105x85	80x60	9	150	<b>8477 UFD 100 P62</b>
125	40	155	45	105x85	80x60	9	250	<b>8477 UFX 125 P62</b>
160	46	195	60	140x110	105x80	11	300	<b>8477 UFX 160 P63</b>
200	46	235	60	140x110	105x80	11	300	<b>8477 UFX 200 P63</b>

## 8470 - P30 UFX RUSTFRIE TRINSER

- Dobbel kulebane i svingkrans rustfrie kuler
- Tetning i svingkrans
- Gaffel og festeplate av presset rustfri stålplate
- Hjul elastisk grå gummi meget myk og lettrullende
- **UFD** elastisk gummi på nylonfelg m/rullelager
- **UFX** elastisk gummi på nylonfelg m/tette kulelager



mm	mm	mm	mm	mm	mm	kg (daN)	Svingbar trinse
100	34	128	40	12		150	<b>8470 UFD 100 P30</b>
125	40	155	45	12		250	<b>8470 UFX 125 P30</b>



mm	mm	mm	mm	mm	mm	kg (daN)	Svingbar trinse m/brems
100	34	128	40	12		150	<b>8477 UFD 100 P30</b>
125	40	155	45	12		250	<b>8477 UFX 125 P30</b>

### ALTERNATIVER



PIO



Retningsslås for P63

## 8470 - P60 UOO RUSTFRIE TRINSER

- Dobbel kulebane i svingkrans rustfrie kuler
- Tetning i svingkrans

- Gaffel og festeplate av presset rustfri stålplate
- Hjul av nylon m/glidelager



mm	mm	mm	mm	mm	mm	mm	kg (daN)	Svingbar trinse
80	34	108	40	105x 85	80x60	9	200	<b>8470 UOO 080 P62</b>
100	35	128	40	105x 85	80x60	9	200	<b>8470 UOO 100 P62</b>
125	40	155	45	105x 85	80x60	9	250	<b>8470 UOO 125 P62</b>
150	40	190	60	140x 110	105x80	11	400	<b>8470 UOO 150 P63</b>
160	40	195	60	140x 110	105x80	11	400	<b>8470 UOO 160 P63</b>
200	50	235	60	140x 110	105x80	11	400	<b>8470 UOO 200 P63</b>



mm	mm	mm	mm	mm	mm	mm	kg (daN)	Fast trinse
80	34	108		105x 85	80x60	9	200	<b>8478 UOO 080 P62</b>
100	35	128		105x 85	80x60	9	200	<b>8478 UOO 100 P62</b>
125	40	155		105x 85	80x60	9	250	<b>8478 UOO 125 P62</b>
150	40	190		140x 110	105x80	11	400	<b>8478 UOO 150 P63</b>
160	40	195		140x 110	105x80	11	400	<b>8478 UOO 160 P63</b>
200	50	235		140x 110	105x80	11	400	<b>8478 UOO 200 P63</b>



mm	mm	mm	mm	mm	mm	mm	kg (daN)	Svingbar trinse m/brems
80	34	108	40	105x 85	80x60	9	200	<b>8477 UOO 080 P62</b>
100	35	128	40	105x 85	80x60	9	200	<b>8477 UOO 100 P62</b>
125	40	155	45	105x 85	80x60	9	250	<b>8477 UOO 125 P62</b>
150	40	190	60	140x 110	105x80	11	400	<b>8477 UOO 150 P63</b>
160	40	195	60	140x 110	105x80	11	400	<b>8477 UOO 160 P63</b>
200	50	235	60	140x 110	105x80	11	400	<b>8477 UOO 200 P63</b>

## 8470 - P30 UOO RUSTFRIE TRINSER

- Dobbel kulebane i svingkrans rustfrie kuler
- Tetning i svingkrans

- Gaffel og festeplate av presset rustfri stålplate
- Hjul **UOO** nylon m/glidelager



mm	mm	mm	mm	mm			kg (daN)	Svingbar trinse
80	34	108	40	12			200	<b>8470 UOO 080 P30</b>
100	35	128	40	12			200	<b>8470 UOO 100 P30</b>
125	40	155	45	12			250	<b>8470 UOO 125 P30</b>



mm	mm	mm	mm	mm			kg (daN)	Svingbar trinse m/brems
80	34	108	40	12			200	<b>8477 UOO 080 P30</b>
100	35	128	40	12			200	<b>8477 UOO 100 P30</b>
125	40	155	45	12			250	<b>8477 UOO 125 P30</b>

### ALTERNATIVE HJUL



IDP Ø100  
Varmebestandig gummi



BOO/BOP  
Varmebestandig



Retningslås for P63

## 8470 - P60 UAO RUSTFRIE TRINSER

- Dobbel kulebane i svingkrans rustfrie kuler
- Tetning i svingkrans

- Gaffel og festeplate av presset rustfri stålplate
- Hjul polyuretanbane på nylonfelg m/glidelager



mm	mm	mm	mm	mm	mm	mm	kg (daN)	Svingbar trinse
80	30	108	40	105x 85	80x60	9	100	<b>8470 UAO 080 P62</b>
100	30	128	40	105x 85	80x60	9	150	<b>8470 UAO 100 P62</b>
125	30	155	45	105x 85	80x60	9	150	<b>8470 UAO 125 P62</b>
125	40	161	60	140x 110	105x80	11	300	<b>8470 UAO 125 P63</b>
150	40	180	40	105x 85	80x60	9	200	<b>8470 UAO 150 P62</b>
160	40	196	60	140x 110	105x80	11	350	<b>8470 UAO 160 P63</b>
200	50	236	60	140x 110	105x80	11	400	<b>8470 UAO 200 P63</b>



mm	mm	mm	mm	mm	mm	mm	kg (daN)	Fast trinse
80	30	108		105x 85	80x60	9	100	<b>8478 UAO 080 P62</b>
100	30	128		105x 85	80x60	9	150	<b>8478 UAO 100 P62</b>
125	30	155		105x 85	80x60	9	150	<b>8478 UAO 125 P62</b>
125	40	161		140x 110	105x80	11	300	<b>8478 UAO 125 P63</b>
150	40	180		105x 85	80x60	9	200	<b>8478 UAO 150 P62</b>
160	40	196		140x 110	105x80	11	350	<b>8478 UAO 160 P63</b>
200	50	236		140x 110	105x80	11	400	<b>8478 UAO 200 P63</b>



mm	mm	mm	mm	mm	mm	mm	kg (daN)	Svingbar trinse m/brems
80	30	108	40	105x 85	80x60	9	100	<b>8477 UAO 080 P62</b>
100	30	128	40	105x 85	80x60	9	150	<b>8477 UAO 100 P62</b>
125	30	155	45	105x 85	80x60	9	150	<b>8477 UAO 125 P62</b>
125	40	161	60	140x 110	105x80	11	300	<b>8477 UAO 125 P63</b>
150	40	180	40	105x 85	80x60	9	200	<b>8477 UAO 150 P62</b>
160	40	196	60	140x 110	105x80	11	350	<b>8477 UAO 160 P63</b>
200	50	236	60	140x 110	105x80	11	400	<b>8477 UAO 200 P63</b>

## 8470 - P30 UAO RUSTFRIE TRINSER

- Dobbel kulebane i svingkrans rustfrie kuler
- Tetning i svingkrans

- Gaffel og festeplate av presset rustfri stålplate
- Hjul **U00** nylon m/glidelager



mm	mm	mm	mm	mm	mm	kg (daN)	Svingbar trinse
80	30	108	40	12		100	<b>8470 UAO 080 P30</b>
100	30	128	40	12		150	<b>8470 UAO 100 P30</b>
125	30	155	45	12		150	<b>8470 UAO 125 P30</b>
150	40	180	45	12		200	<b>8470 UAO 150 P30</b>



mm	mm	mm	mm	mm	mm	kg (daN)	Svingbar trinse m/brems
80	30	108	40	12		100	<b>8477 UAO 080 P30</b>
100	30	128	40	12		150	<b>8477 UAO 100 P30</b>
125	30	155	45	12		150	<b>8477 UAO 125 P30</b>
150	40	180	45	12		200	<b>8477 UAO 150 P30</b>

### ALTERNATIVE HJUL



UAD  
m/rustfritt rullelager











Retningslås for P63

## 8670 - TOO RUSTFRIE TRINSER KRAFTIG MODELL







- Dobbel kulebane i svingkrans rustfrie kuler
- Tetning i svingkrans

- Gaffel og festeplate av presset rustfri stålplate
- Hjul av nylon kraftig serie **TOO**











 mm	 mm	 mm	 mm	 mm	 mm	 mm	 kg (daN)	Svingbar trinse
125	50	164	55	140x110	105x80	11	700	<b>8670 TOO 125 P63</b>
160	50	200	55	140x110	105x80	11	800	<b>8670 TOO 160 P63</b>
200	50	240	55	140x110	105x80	11	800	<b>8670 TOO 200 P63</b>



 mm	 mm	 mm		 mm	 mm	 mm	 kg (daN)	Fast trinse
125	50	164		140x110	105x80	11	700	<b>8678 TOO 125 P63</b>
160	50	200		140x110	105x80	11	800	<b>8678 TOO 160 P63</b>
200	50	240		140x110	105x80	11	800	<b>8678 TOO 200 P63</b>



 mm	 mm	 mm	 mm	 mm	 mm	 mm	 kg (daN)	Svingbar trinse m/brems
125	50	164	55	140x110	105x80	11	700	<b>8677 TOO 125 P63</b>
160	50	200	55	140x110	105x80	11	800	<b>8677 TOO 160 P63</b>
200	50	240	55	140x110	105x80	11	800	<b>8677 TOO 200 P63</b>

### ALTERNATIVE HJUL



UAO

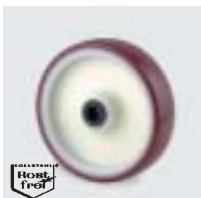

UAD



UFX

### ALTERNATIVER



Retningslås 8671

## **1. Leveringsbetingelser**

Rettsforholdet mellom kjøper og A.C.LANDGRAFF AS (ACL) bedømmes etter norsk lov med nedenforstående endringer.

## **2. Tilbud og priser**

Muntlige tilbud skal aksepteres straks, ellers er de å regne som bortfalt. Skriftlige tilbud er gjeldende i 28 dager etter tilbudsdato såfremt annet ikke er notert, deretter er tilbudet bortfalt. Prisen er forbeholdt for lønns- og materialpris-stigning samt svingninger i valutakursene.

## **3. Levering**

Levering skjer med mindre annet er avtalt fritt vårt lager. Spesialproduserte varer, herunder spesialfarver kan over/under leveres med 10%

Ordre under det til enhver tid gjeldende minimum kjøp tillegges det til enhver tid gjeldende småordretillegg. Pr. i dag tillegges ordre under kr. 300,- et tillegg på kr. 40,-.

Retur av varer kan kun skje etter avtale og skal da sendes fritt vårt lager. Ved retur beregnes et returgebyr på 10% dog minimum kr. 150,-.

## **4. Mangler og ansvar**

Reklamasjoner over antallsmangler skal skje straks etter mottagelsen av varene ellers bortfaller reklamasjonsretten. Reklamasjoner over øvrige mangler skal skje innen 8 dager fra mottagelsen ellers bortfaller reklamasjonsretten. Vårt ansvar er begrenset til ny levering med reklamasjonsfri vare eller maksimert til faktura-beløpet, etter vårt valg.

## **5. Force majeure**

Følgende utvidede force majeure fritar ACL for forsinkelsesansvar: Krig, brann, streik, lockout, vær, ut-og innførselsforbud, beslagleggelser eller forsinkelser fra underleverandører eller andre omstendigheter som ACL ikke forutså eller burde ha forutsett.

## **6. Produktansvar**

Selgeren er ikke ansvarlig for skade på produkter som er fremstilt av kjøperen. Selgeren er ikke ansvarlig for driftstap, tapt arbeidsfortjeneste eller annet indirekte tap.

## **7. Generelt**

Alle mål, farveangivelser, belastningsoppgaver m.m. kan endres uten forvarsel.

## **8. Kvalitetssikring**

De fleste av våre leverandører er ISO 9001-sertifisert.

**A.C. Landgraff AS**

P. boks 14, N-1305 Haslum  
Nesveien 13, N-1344 Haslum  
Tlf.: (+47) 67 52 60 00  
Faks: (+47) 67 53 88 12  
e-post: [landgraff@landgraff.no](mailto:landgraff@landgraff.no)  
[www.landgraff.no](http://www.landgraff.no)